

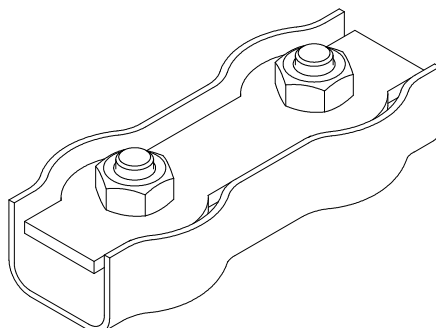



**TABELLA TECNICA  
MORSETTI DUPLEX ART. 8317-D**

Indicazioni di smaltimento imballaggi		
Simbolo	Indicazioni raccolta	
		
		Raccolta carta: cartone ondulato (scatole imballaggio)
Verifica le disposizioni del tuo comune		

- 1) Acciaio impiegato: Fe P11 UNI 5867
- 2) Trattamento Superficiale: Zincatura Fe /Zn 5 c 1A UNI 3740/6
- 3) Il collaudo viene eseguito in base a specifiche e regole interne in riferimento alla norma UNI EN ISO 9001.

**4) Istruzioni Operative:**

- L'articolo non deve essere utilizzato nel caso di usura o presenza di eventuali cricche
- I dati indicati si riferiscono all'utilizzo del prodotto a temperature comprese tra -20°C e +80°C
- Ispezionare sempre il prodotto prima dell'utilizzo.

**5) Marcatura: Diametro della fune da utilizzare.****ATTENZIONE**



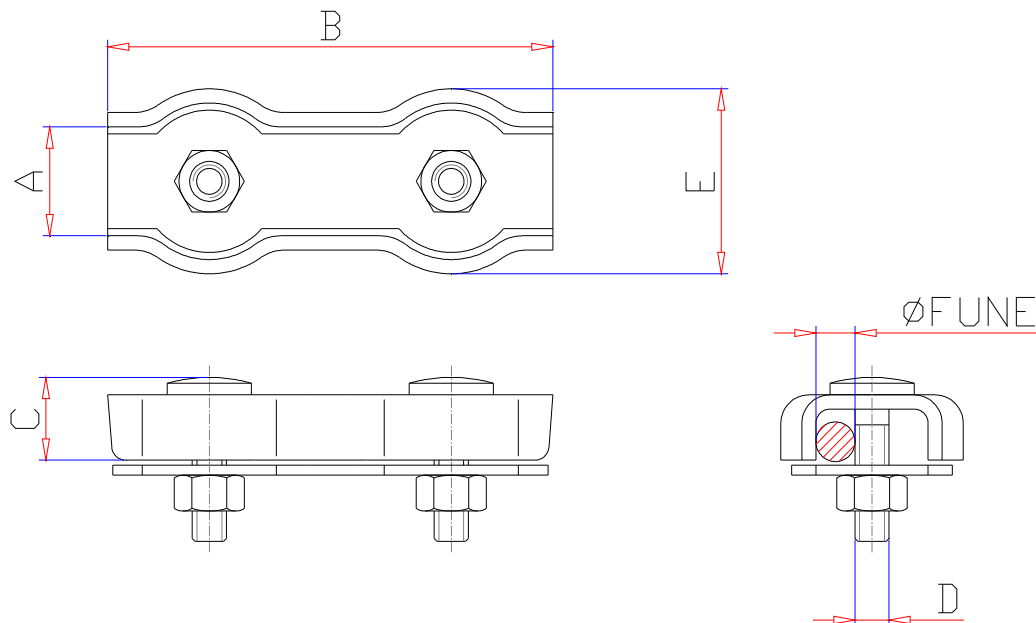

Questo documento è valido fino a che permangono inalterate le nostre condizioni tecniche di fornitura. Eventuali modifiche, lavorazioni, trattamenti successivi, ci esonerano da qualsiasi responsabilità.

**TABELLA TECNICA  
MORSETTI DUPLEX ART. 8317-D**

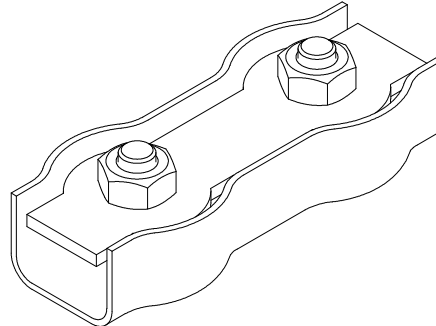
Le quote indicate sono espresse in mm.

Ø FUNE	A	B	C	D	E	g	CODICE
2	5	30	6	M4	14	10	083170002
3	6	35	7	M4	15	12	083170003
4	8	40	8	M5	18	22	083170004
5	10	50	9	M5	21	28	083170005
6	12	60	11	M6	25	40	083170006
8	18	76	12	M8	33	90	083170008
10	22	95	16	M10	37	170	083170010

**TECHNICAL TABLE  
WIRE ROPE CLIPS DUPLEX ITEM 8317-D**

Disposal packaging instruction		
Simbology		Collection indication
		
		Paper collection: corrugated cardboard (packaging boxes)
Check the provisions of your country.		

- 1) Steel type used: Fe P11 UNI 5867
- 2) Surface treatment: galvanized Fe/Zn 5 c 1A UNI 3740/6
- 3) The inspection is performed in accordance with specifications and in-house regulations referring to the UNI EN ISO 9001 standard.
  
- 4) Operating instructions:
  - This item should not be used if it is worn or cracked.
  - The indicated data are referred to products used at a temperature between -20°C e +80°C
  - Before using the product always check it.
  
- 5) Marking: Diameter of rope to use.

**WARNING!**

This document shall be valid until our technical terms and conditions are changed.

We shall not be liable for any subsequent modifications, working techniques and treatments.

For any controversy refer to technical table written in Italian.

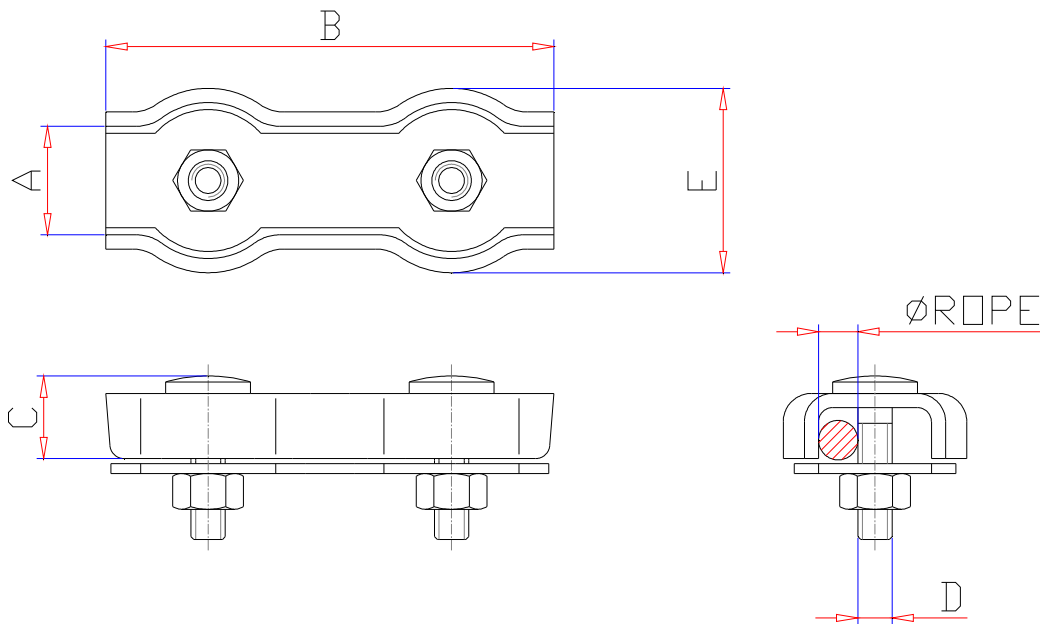
**TECHNICAL TABLE  
WIRE ROPE CLIPS DUPLEX ITEM 8317-D**

The dimensions are expressed in mm.

Ø ROPE	A	B	C	D	E	g	CODE
2	5	30	6	M4	14	10	083170002
3	6	35	7	M4	15	12	083170003
4	8	40	8	M5	18	22	083170004
5	10	50	9	M5	21	28	083170005
6	12	60	11	M6	25	40	083170006
8	18	76	12	M8	33	90	083170008
10	22	95	16	M10	37	170	083170010